

PROPRIETARY AND CONFIDENTIAL

THE INFORMATION CONTAINED IN THIS DRAWING IS THE SOLE PROPERTY OF DYTRAN INSTRUMENTS INC. ANY REPRODUCTION IN PART OR AS A WHOLE WITHOUT THE WRITTEN PERMISSION OF DYTRAN INSTRUMENTS INC. IS PROHIBITED

REVISIONS

REV	ECN	DESCRIPTION	BY/DATE	CHK	APPR
C	14567	SEE ECN	AM 10/01/18	EM	LD

MODEL	SENSITIVITY
3215A1	10 mV/g
3215A2	50 mV/g

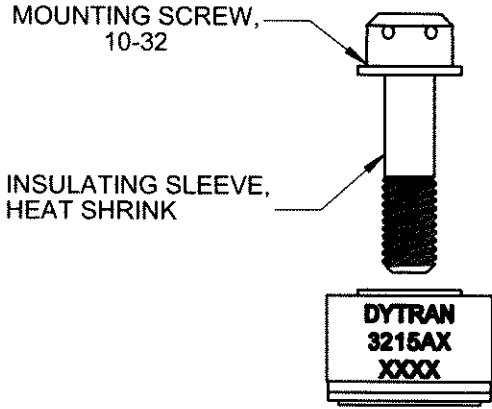
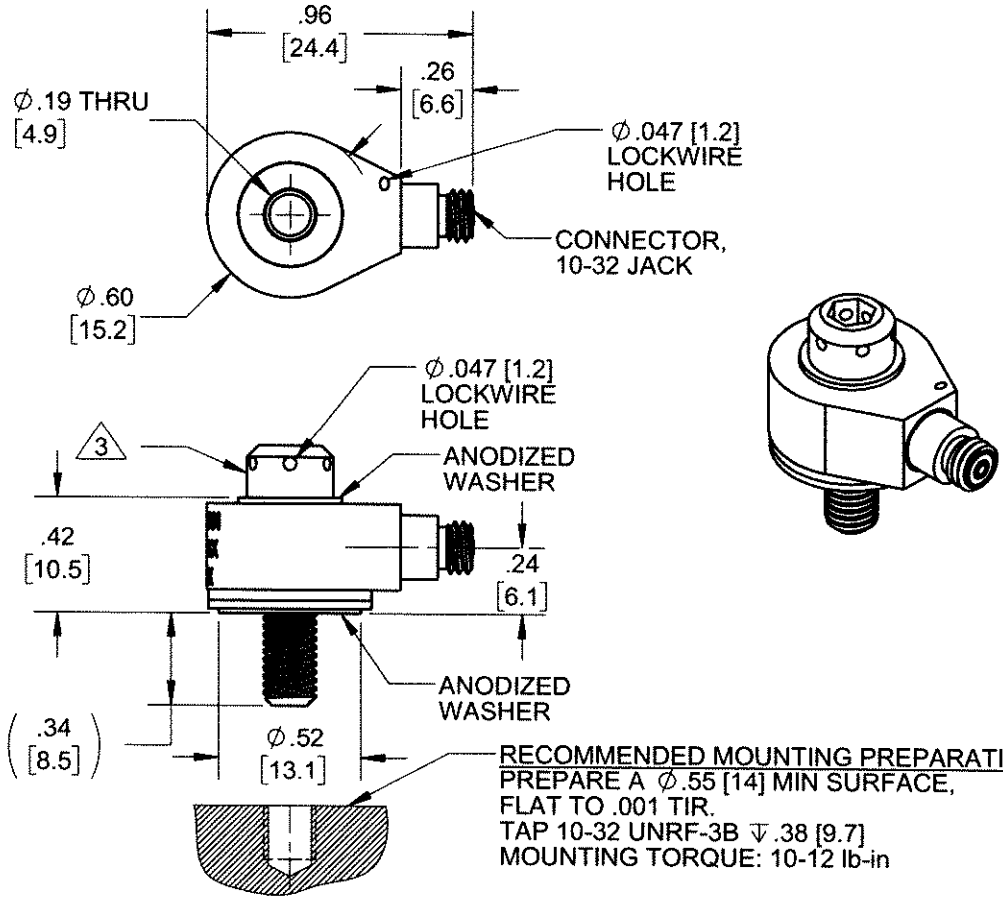

- 3. MOUNTING SCREW, MODEL 6368, 10-32 X .75 [19.1] LONG, WITH INSULATING SLEEVE, SUPPLIED
- MOUNTING SCREW, MODEL 69075, 10-32 X .75 [19.1] LONG, WITHOUT LOCK WIRE HOLES, AVAILABLE.
- 2. HOUSING/CONNECTOR MATERIAL: TITANIUM ALLOY
- 1. WEIGHT: 8.0 GRAMS, MAX.

NOTES: UNLESS OTHERWISE SPECIFIED

USED ON	NEXT ASSY	UNLESS OTHERWISE SPECIFIED: INTERPRET DIM & TOL PER ASME Y14.5M - 1994. REMOVE BURRS. COUNTERSINK INTERNAL THDS 90° TO MAJOR DIA. CHAM EXT THDS 45° TO MINOR DIA. THD LENGTHS AND DEPTHS ARE FOR MIN FULL THDS. THDS PER MIL-S-7742. DIMENSIONS APPLY AFTER FINISHING.
APPLICATION		
THIRD ANGLE PROJECTION USA		ALL MACHINED SURFACES TOTAL RUNOUT WITHIN .005. BREAK SHARP EDGES .005 TO .010. MACHINED FILLET RADII .005 TO .015. WELDING SYMBOLS PER AWS A2.4. ABBREVIATIONS PER MIL-STD-12.

UNLESS OTHERWISE SPECIFIED: DIMENSIONS ARE IN INCHES. DIMENSIONS IN BRACKETS [] ARE IN MILLIMETERS. TOLERANCES ARE: INCHES METRIC ANGLES .XX ± .03 X ± 0.8 ± 1° .XXX ± 0.10 .XX ± 0.25		
MATERIAL		
FINISH		
DO NOT SCALE DRAWING		

CONTRACT NO.		
APPROVALS		DATE
ORIG	LN	12/23/14
CHK	AS	02/05/16
APP	EM	02/11/16
APP		

DYTRAN INSTRUMENTS, INC. Chatsworth, CA

MASTER ONLY IF IN RED

TITLE: **OUTLINE/INSTALLATION DWG, MODELS 3215A1**

SIZE A	CAGE CODE 2W033	DWG. NO. 127-3215A1	REV C
SCALE: NONE		SOLIDWORKS	SHEET 1 OF 1

Model Number
3215A2

PERFORMANCE SPECIFICATION

DOC NO
PS3215A2

MINIATURE IEPE ACCELEROMETER

REV D, ECN 15467, 12/12/19

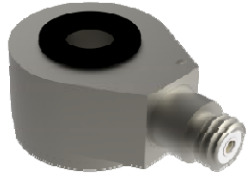

- MINIATURE SIZE
- HERMETICALLY SEALED
- GROUND ISOLATED

PHYSICAL

Weight, Max
Connector, Side Mounted
Mounting Provision, Thru Hole
Material, Housing/Connector
Sensing Element
Element Style

ENGLISH		SI	
0.28	oz	8.0	grams
10-32 Jack		10-32 Jack	
Ø .19	Inches	Ø 4.8	mm
Titanium Alloy		Titanium Alloy	
Quartz		Quartz	
Shear		Shear	

PERFORMANCE

Sensitivity, ±5% [1]
Range F.S for ± 5 Volts Output
Frequency Response, ±5%
Frequency Response, ±10%
Frequency Response, ±3dB%
Resonant Frequency
Equivalent Electrical Noise Floor, Max.
Linearity [2]
Maximum Transverse Sensitivity
Strain Sensitivity @ 250µε

50	mV/g	5.1	mV/m/s ²
± 100	g	± 981	m/s ²
1.6 to 10,000	Hz	1.6 to 10,000	Hz
1.1 to 15,000	Hz	1.1 to 15,000	Hz
0.6 to 19,000	Hz	0.6 to 19,000	Hz
>50	kHz	>50	kHz
0.002	Grms	0.02	m/s ² rms
± 1%	% F.S.	± 1%	% F.S.
5	%	5	%
0.003	g/µε	0.03	m/s ² /µε

ENVIRONMENTAL

Maximum Vibration
Maximum Shock
Temperature Range
Seal

± 250	Gpeak	± 2453	m/s ² peak
± 1000	Gpeak	± 9810	m/s ² peak
-67 to +300	°F	-55 to +149	°C
Hermetic		Hermetic	

ELECTRICAL

Supply Current Range [3]
Compliance Voltage Range
Output Impedance, Typ
Bias Voltage
Discharge Time Constant
Isolation, Case to mounting surface, Min.

2 to 20	mA	2 to 20	mA
+18 to +30	VDC	+18 to +30	VDC
120	Ω	120	Ω
7.0 to 9.0	VDC	7.0 to 9.0	VDC
0.3 to 2.0	Sec	0.3 to 2.0	Sec
10	GΩ	10	GΩ

This family also includes:

Model	Sensitivity (mV/g)	Frequency Response, ±5% (Hz)	Time Constant (Sec)	Operating Temp (°F)
3215A1	10	1 to 10,000	0.3 to 2.0	-60 to +300

Refer to the performance specifications of the products in this family for detailed description.

Supplied Accessories:

- 1) Accredited calibration certificate (ISO 17025)
- 2) Mounting Screw, Model 6368, Qty: 1

Accessories Available:

- 1) Mounting Screw, Model 69075 (No lock wire holes)

Notes:

- [1] Measure at 100Hz, 1 Grms per ISA RP 37.2
- [2] Measure using zero-based straight line method, % of F.S. or any lesser range.
- [3] Do not apply power to this system without current limiting, 20 mA MAX. To do so will destroy the IC charge amplifier
- [4] In the interest of constant product improvement, we reserve the rights to change the specifications without notice.

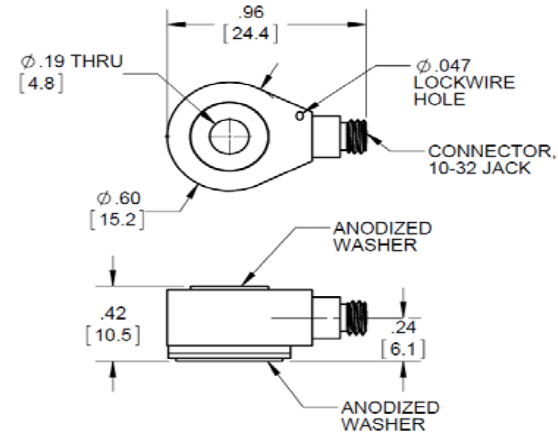
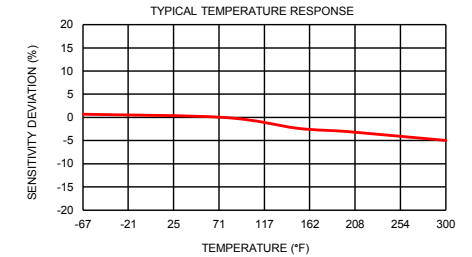
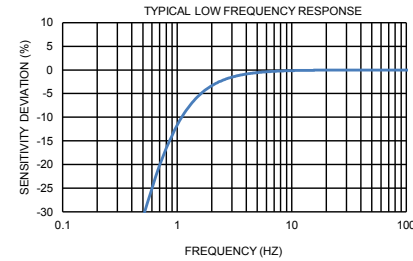

Units on the line drawing are in inches, units in brackets are in millimeters. Refer to 127-3215A1 for more information.



21592 Marilla Street, Chatsworth, California 91311 Phone: 818.700.7818 Fax: 818.700.7880 www.dytran.com
For permission to reprint this content, please contact info@dytran.com